

SECTION A-A

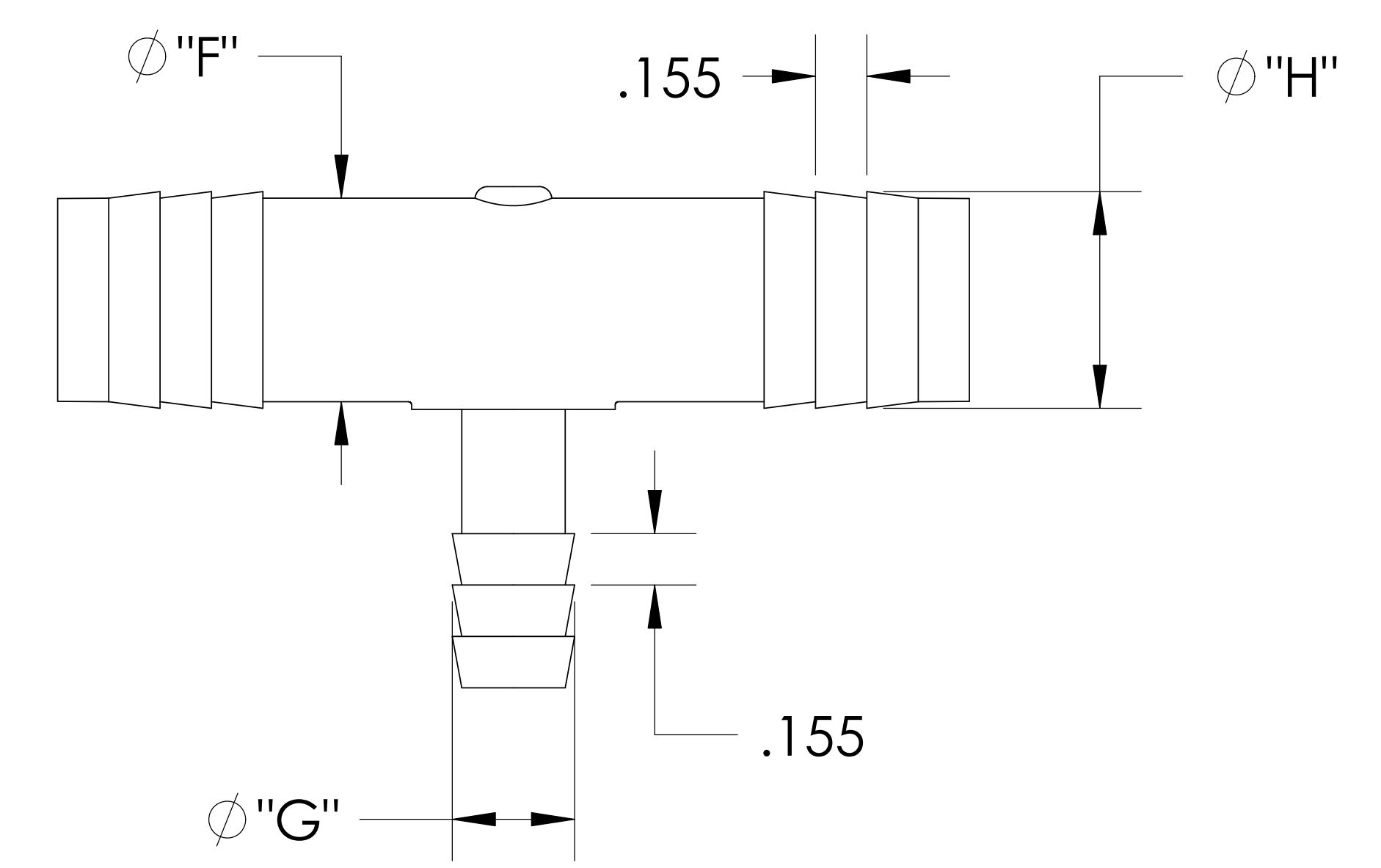
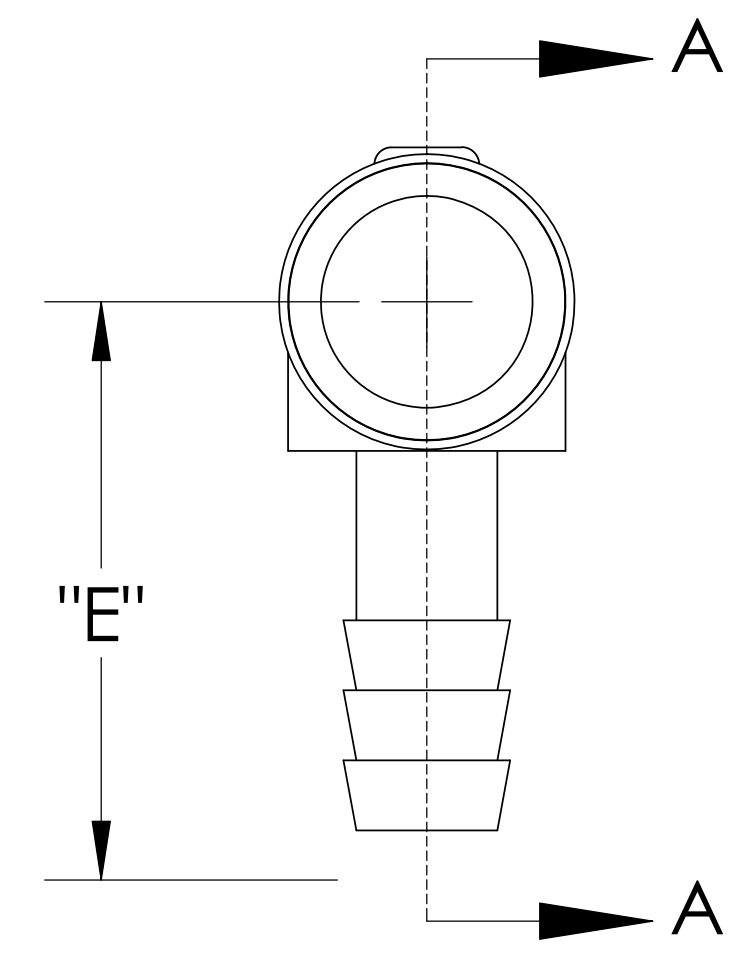

CATALOG NO.	DESCRIPTION	MATERIAL	DIM "A"	DIM "B"	DIM "C"	DIM "D"	DIM "E"	DIM "F"	DIM "G"	DIM "H"
TT951010/PP	5/16 X 5/8 X 5/8 PP	POLYPROPYLENE	.460	2.72	.305	.215	1.17	.600	.360	.650
TT951010/N	5/16 X 5/8 X 5/8 N	NYLON	.469	2.75	.315	.220	1.28	.614	.369	.654

SHOWN

NOTES:
 1) POLYPROPYLENE HAS COLOR OPTIONS:
 BLACK = TT951010/PPB
 NATURAL = TT951010/PPN

PROPRIETARY AND CONFIDENTIAL
 THE INFORMATION CONTAINED IN THIS DRAWING IS THE SOLE PROPERTY OF THOGUS PRODUCTS COMPANY. ANY REPRODUCTION IN PART OR AS A WHOLE WITHOUT THE WRITTEN PERMISSION OF THOGUS PRODUCTS COMPANY IS PROHIBITED.

REV	WRO#	DESCRIPTION
	C	95.00053 CONVERTED TO 3D FORMAT
HISTORY		

UNLESS OTHERWISE SPECIFIED:		
DIMENSIONS ARE IN INCHES		
TOLERANCES:		
ANGULAR: ±0.5°		
X.X = ± 0.1		
X.XX = ± 0.05		
X.XXX = ± 0.015		
REMOVE ALL SHARP EDGES AND BURRS		
BLEND ALL RADII TO 0.01IN		
INTERPRET GEOMETRIC TOLERANCING PER: ANSI Y 14.5 1994		
MATERIAL: PP, N		
FINISH: NA		
THIRD ANGLE PROJECTION:		
NAME	DATE	
DRAWN	KDJ	12/28/10
CHECKED	KDJ	12/28/10
ENG APPR.		XX/XX/XX
MFG APPR.		XX/XX/XX
Q.A.		XX/XX/XX
COMMENTS:		
DO NOT SCALE DRAWING		

Thogus You think it, we can make it...
 33490 PIN OAK, AVON LAKE, OH 44012
TITLE:
 5/16 BARB X 5/8 BARB X 5/8 BARB TEE
SIZE B **DWG. NO.** TT951010 **REV** B
SCALE: 1:1 **MASS:** **SHEET** 1 OF 1