

UNCONTROLLED IF PRINTED; CONTROLLED COPY LOCATED IN IQMS DOCUMENT CONTROL

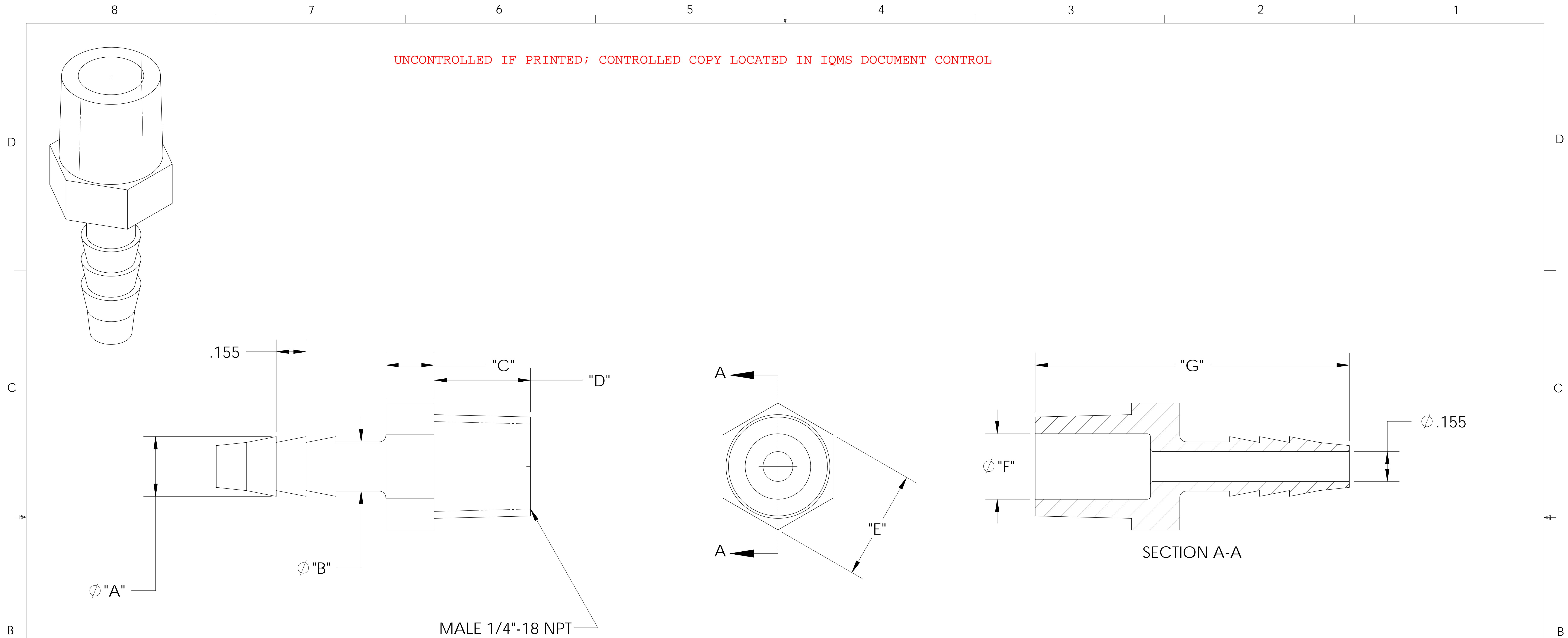

CATALOG NO.	DESCRIPTION	MATERIAL	DIM "A"	DIM "B"	DIM "C"	DIM "D"	DIM "E"	DIM "F"	DIM "G"
TA1044/PP	1/4" NPT X 1/4" PP	POLYPROPYLENE	.310	.250	.250	.50	.56	.335	1.56
TA1044/P	1/4" NPT X 1/4" P	POLYETHYLENE	.305	.250	.245	.49	.55	.335	1.57
TA1044/N	1/4" NPT X 1/4" N	NYLON	.310	.255	.250	.50	.57	.340	1.63

SHOWN

NOTES:
 1) POLYPROPYLENE HAS COLOR OPTIONS:
 BLACK = TA1044/PPB
 NATURAL = TA1044/PPN

PROPRIETARY AND CONFIDENTIAL
 THE INFORMATION CONTAINED IN THIS DRAWING IS THE SOLE PROPERTY OF THOGUS PRODUCTS COMPANY. ANY REPRODUCTION IN PART OR AS A WHOLE WITHOUT THE WRITTEN PERMISSION OF THOGUS PRODUCTS COMPANY IS PROHIBITED.

D	95.00072	CONVERTED TO 3D FORMAT	UNLESS OTHERWISE SPECIFIED: DIMENSIONS ARE IN INCHES TOLERANCES: ANGULAR: ±0.5° XX = ± 0.1 X.XX = ± 0.05 X.XXX = ± 0.015 REMOVE ALL SHARP EDGES AND BURRS BLEND ALL RADII TO 0.01IN INTERPRET GEOMETRIC TOLERANCING PER: ANSI Y 14.5 1994 MATERIAL: PP, P, N FINISH: NA THIRD ANGLE PROJECTION: 	NAME	DATE	 33490 PIN OAK, AVON LAKE, OH 44012 TITLE: 1/4" NPT X 1/4" BARB ADAPTER SIZE B DWG. NO. TA1044 REV D SCALE: 2:1 MASS: SHEET 1 OF 1	
				DRAWN	JRM		03/16/11
				CHECKED	KDJ		03/17/11
				ENG APPR.	JM		03/17/11
				MFG APPR.	ML		03/17/11
			Q.A.	NJW	03/17/11		
REV	WRO#	DESCRIPTION	COMMENTS:				
HISTORY			DO NOT SCALE DRAWING				