

UNCONTROLLED IF PRINTED; CONTROLLED COPY LOCATED IN IQMS DOCUMENT CONTROL

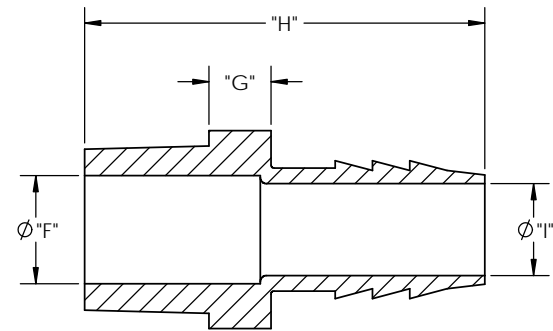
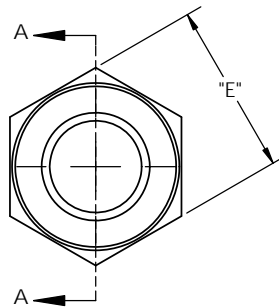
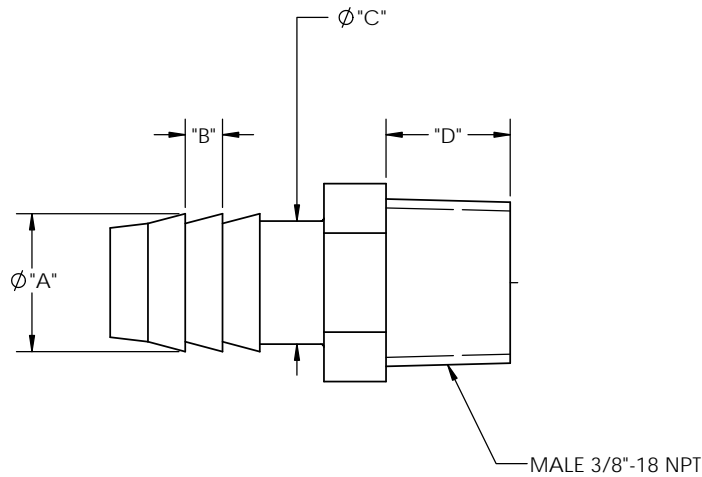
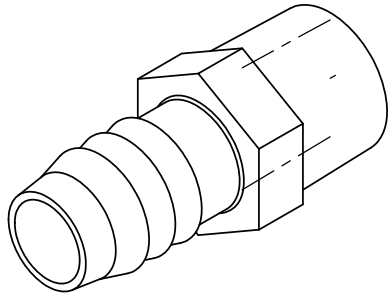

SECTION A-A

CATALOG NO.	DESCRIPTION	MATERIAL	DIM "A"	DIM "B"	DIM "C"	DIM "D"	DIM "E"	DIM "F"	DIM "G"	DIM "H"	DIM "I"
TA1068/PP	3/8" NPT X 1/2" PP	POLYPROPYLENE	.545	.155	.490	.49	.68	.430	.245	1.59	.370
TA1068/P	3/8" NPT X 1/2" P	POLYETHYLENE	.540	.140	.495	.48	.68	.420	.245	1.56	.360
TA1068/N	3/8" NPT X 1/2" N	NYLON	.555	.150	.495	.50	.69	.435	.250	1.61	.370

SHOWN

NOTES:

- 1) POLYPROPYLENE HAS COLOR OPTIONS:
 BLACK = TA1068/PPB
 NATURAL = TA1068/PPN

PROPRIETARY AND CONFIDENTIAL
 THE INFORMATION CONTAINED IN THIS DRAWING IS THE SOLE PROPERTY OF THOGUS PRODUCTS COMPANY. ANY REPRODUCTION IN PART OR AS A WHOLE WITHOUT THE WRITTEN PERMISSION OF THOGUS PRODUCTS COMPANY IS PROHIBITED.

REV	WRO#	DESCRIPTION
D	95.00072	CONVERTED TO 3D FORMAT

UNLESS OTHERWISE SPECIFIED:
 DIMENSIONS ARE IN INCHES
 TOLERANCES:
 ANGULAR: $\pm 0.5^\circ$
 XX = ± 0.1
 XXX = ± 0.05
 XXXX = ± 0.015
 REMOVE ALL SHARP EDGES AND BURRS
 BLEND ALL RADII TO 0.01IN
 INTERPRET GEOMETRIC TOLERANCING PER ANSI Y 14.5 1994
 MATERIAL: PP, P, N
 FINISH: NA
 THIRD ANGLE PROJECTION:

NAME	DATE
DRAWN: JRM	03/17/11
CHECKED: KDJ	3/17/11
ENG APPR: JM	3/17/11
MFG APPR: ML	3/18/11
Q.A. NJW	3/18/11

Thogus You think it, we can make it.
 33490 PIN OAK, AVON LAKE, OH 44012
 TITLE: 3/8" NPT X 1/2" BARB ADAPTER

SIZE B	DWG. NO. TA1068	REV D
DO NOT SCALE DRAWING	SCALE: 2:1	MASS:
		SHEET 1 OF 1